



BBQ ENG.ver CATALOG EXHAUST HOOD



version : November. 2025



Gaon Trading Co., Ltd. serves all areas of commercial kitchen facilities. Specializing in commercial kitchen solutions, we offer top-notch expertise in a wide range of areas, from the production of kitchen equipment to delivery, export, and restaurant startup consulting.

In particular, with the rapid rise of the K-BBQ market, we have successfully entered the global market by exporting exhaust hoods manufactured directly in Korea to the North American market.

Since our transition to a corporation in November 2023, we have opened a North American branch to further enhance work efficiency and provide the best service to our customers. With a service mindset that values our customers' time, we promise to always strive to meet your needs.

We look forward to becoming your best partner.

INDEX

04 GREETING & HISTORY

05 PATENT & CERTIFICATION

06 PARTNERS & DSITRIBUTOR

12 PRODUCT (SAVOR X MONSTER DETACH PRO)

22 PRODUCT (ROASTER)

23 PRODUCT (GRILL)



Homepage



Youtube(SavorX)



Website for USA



www.gaonhoods.com (ENG) / www.gaoncook.com (한국어)



gaon.office01@gmail.com



Office (+82)62-719-3030 Fax (+82)62-719-3039

Dir (+82)10-5426-1299



[gaontrading](https://www.instagram.com/gaontrading)

Hello,

I am Hanman Lee, the CEO of Gaon Trading Co., Ltd.

As a company specializing in the export of kitchenware, we started with the motto of valuing our customers' time.

Based on our expertise in the foodservice industry, we provide customized products and export them to various countries, including the United States.

Our management philosophy is centered on communication among employees, aiming to create a positive organizational culture that promotes collaboration and efficiency.

We strive to establish a virtuous cycle where our team works together to deliver the best results to our customers. Through this approach, we understand our customers' needs, enhance our competitive quality, and work towards becoming a recognized company in the global market.

We promise to meet our customers' needs and ensure that our products are remembered worldwide.

Thank you.



History

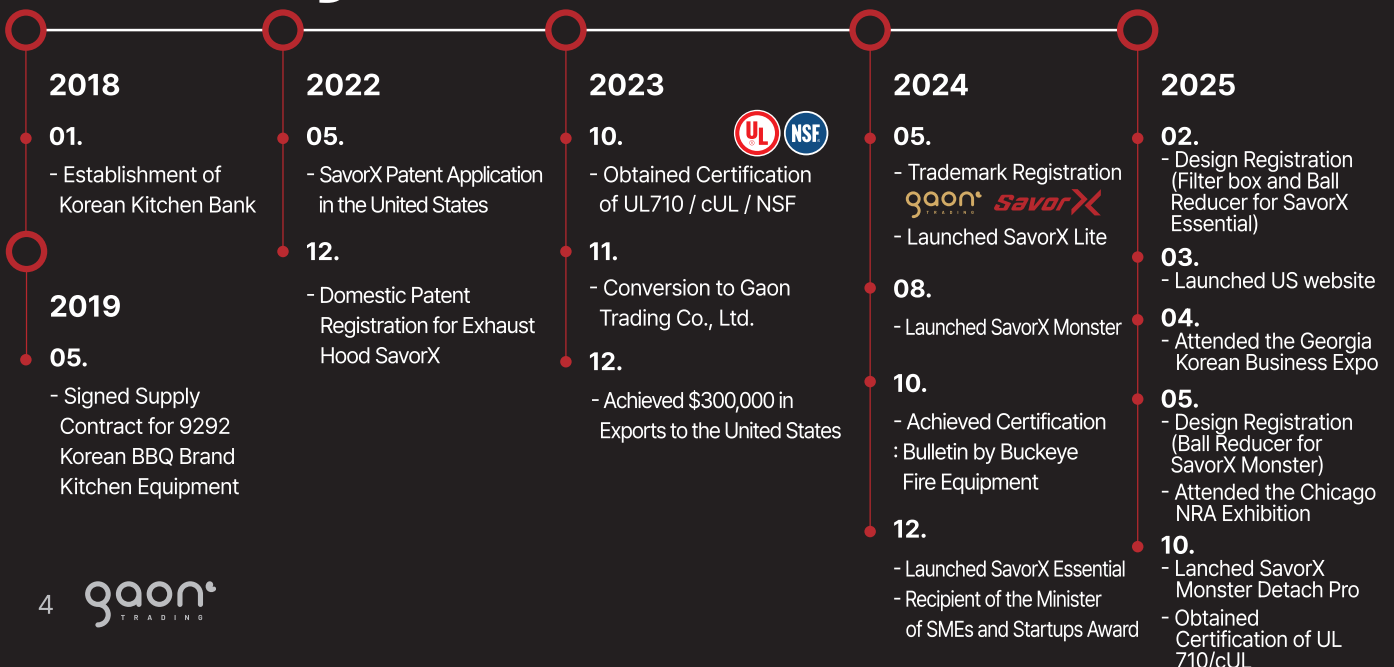

Patent & Certification

CERTIFICATION



UL Certification

Certified by Buckeye Fire Equipment for Kitchen Mister Fire Suppression System



NSF (SavorX Monster Detach Pro)



UL710 (SavorX Monster Detach Pro)



UL710 (SAFETY)



cUL (SAFETY)



NSF (HYGIENE)



ISO 9001



ISO14001



cUL (SavorX Monster Detach Pro)

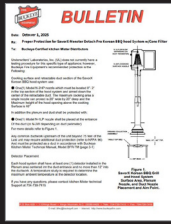

BULLETIN SavorX Monster Detach Pro

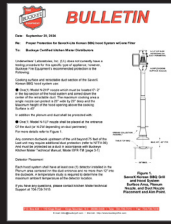

BULLETIN SavorX Lite

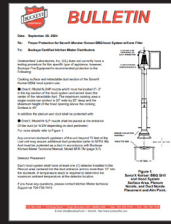

BULLETIN SavorX Monster

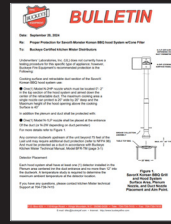

BULLETIN SavorX Essential



Venture Business Certification

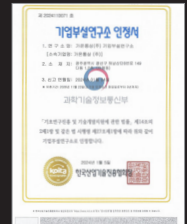

Certificate of Approval for Research Institute



AWARDS



Certificate of Commendation (Minister of SMEs and Startups Commendation Plaque)

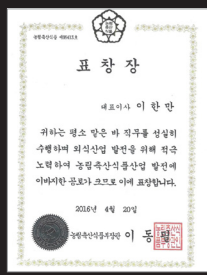

Certificate of Commendation (by the Minister of Agriculture, Food and Rural Affairs)



Award of Merit (by the Korea Foodservice Industry Association)

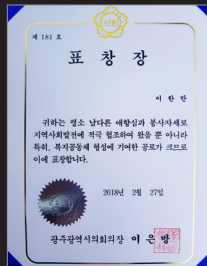

Certificate of Commendation (by the Gwangju Metropolitan Council)

PATENT



EXHAUST HOOD



TRADEMARK (USPTO)

Design Registration



Filter Box for Exhaust Hood



Ball Reducer for Exhaust Hood

Partners & Distributors







Immediate Impact, Lasting Results With Gaon BBQ Exhaust Hood

Lower Operational Costs, Higher Customer Satisfaction

Optimized Solutions for BBQ Restaurants
A Comparative Case Study: 50-Table Installation in the U.S.

Item	Conventional System	Savor X Monster Detach Pro	Savings
Required Air Volume(CFM)	164 CFM	139 CFM	More Efficient
Required Number of Fans(1HP)	9 units	7 units	Down ↓
Fan Cost(*Avg. Cost = \$1,500/unit)	\$13,500	\$10,500	
Required Number of HVAC(3RT)	7 units	6 units	Down ↓
HVAC Cost(*Avg. Cost = \$4,800/unit)	\$33,600	\$28,800	
✓ Total Installation Cost	\$47,100	\$39,300	Saved!!

RT: Refrigeration Ton / 1RT=400 CFM
HP: Horsepower / 1HP = 1000 CFM



Slash your equipment expenses by \$7,180!!!

HVAC system Capacity	Number of installation	Total power Consumption (10h operation)	Electricity Cost/Day	Electricity Cost/Year
3RT	7	315 kWh	\$40.95	\$14,943.75
	6	270 kWh	\$35.10	\$12,808.92

Power Consumption: 1.5 kW per RT
Average Commercial Electricity Rate: \$0.13 per kWh

Electricity savings of \$2,135!!!



Gain a Competitive Edge

■ Certified Safety for Reliable Performance

- Ensuring Product Safety



■ Offering a Superior User Experience

- The wing-nut detachable design of the filter box and pipe ensures convenient and smooth operation.
- Efficient Hygiene Management – UL-certified filter box and detachable outer pipe design for easy cleaning.



- Enhanced Operability with Precision Ball Bearing Design



■ Reduced Resistance Using a Patented Filter

- Enhancing Energy Efficiency by Optimizing Airflow

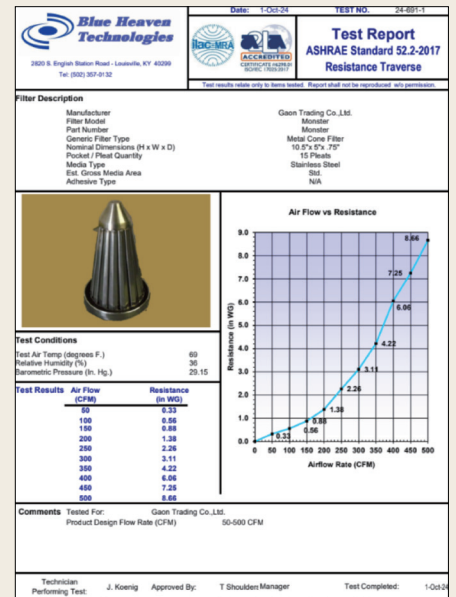

■ Effortless Cleaning with Easy-Detachable System

- Detachable Inner and Outer Filters & Pipes



■ Enhanced Oil Fume Absorption



7.8 in

- Big Grease Tray. Clean Air. 99.9% Oil Vapor Gone.

■ Simplified Maintenance



150ML

- Twice the Filter Life Thanks to the 150ML Capacity Tray



Alberta, Canada



9292 KOREAN BBQ

Georgia, USA



KOREAN BBQ **지수**
JINSOO

Illinois, USA



HONEY PIG

Maryland, USA



조선화로 **朝鮮**
CHOSUNHWARO KOREAN BBQ

Virginia, USA



SHINHWA
KOREAN STEAKHOUSE

Illinois, USA



달동네
Daldongnae

Quebec, Canada



Galbi **갈비**
KOREAN B-B-Q

Vancouver, Canada



Mountain San BBQ

LA, USA



SavorX Showed Up - and Stood out

Where We Made Waves in 2022~2025

2022. 11



2024. 10

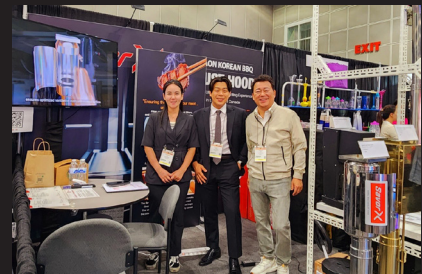

2025. 04



2025. 05



Successfully presented at Global Industry Shows
 See how **SavorX** is defining the future of kitchen ventilation.
 Let's Connect - we're just getting started.

Savor X Monster Detach pro

FEATURES

Length	265×265×1,340~1,710mm
Weight	13kg
Special Features	Possibility of fire prevention with a fires suppression box Adjustable length hood Easy detachment for separate cleaning
Material	SUS304
Airflow	139CFM
Surface Temperature	655F (MAX)
Capacity of Grease collector	150ML
Pipe Detachment	Possible
Filter Box Detachment	Possible
Additional Option	Trumpets, Spring Ballencer
Load Capacity per pallet	18PCS

Officially Certified by an Authorized Institution



Additional Accesories



Inlet cap & Bottom Grease collector

Filter Grease Collector

Grease Guard

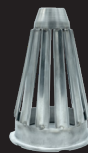

Wing nut

Ball bearings

Spring Balancer

Filter



Basic Ver. ▶



Gold Ver. ▶

✓ CHECK POINT

- ✓ **Filter Box** : The square filter box design prevents the swirling of vapors and provides ample internal space, making it easier to install a fire suppression system.
- ✓ **Wing Nut** : Allow for easy and convenient attachment and detachment of the filter box and pipe
- ✓ **Ball Bearing Coupling** : Allows for easy and convenient attachment and detachment of the vertical and horizontal pipes.
- ✓ **Stainless Steel Single-Material Handle** : Made from a single material to prevent rapid temperature changes, ensuring safe operation during cooking without the risk of burns.
- ✓ **Spring Balancer** : In addition to the ball bearing coupling, installing a spring balancer makes the telescoping much smoother and the tension stronger.



Drawing sheet



Caution

This document was provided for general model information.

The length of the pipe may differ from that of the document, depending on the request of the customer.

Please measure the product received before installation once again.

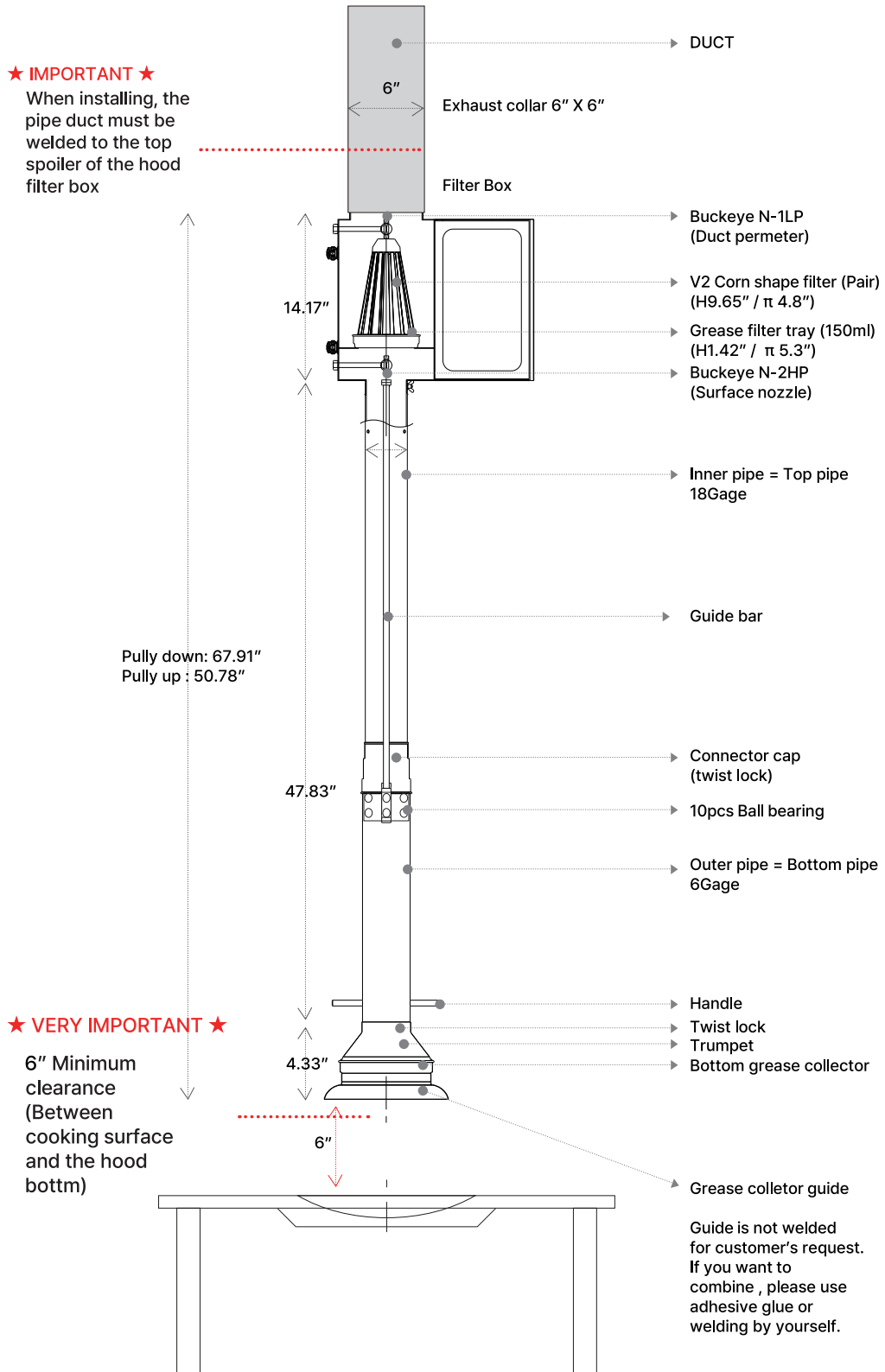

Product Composition

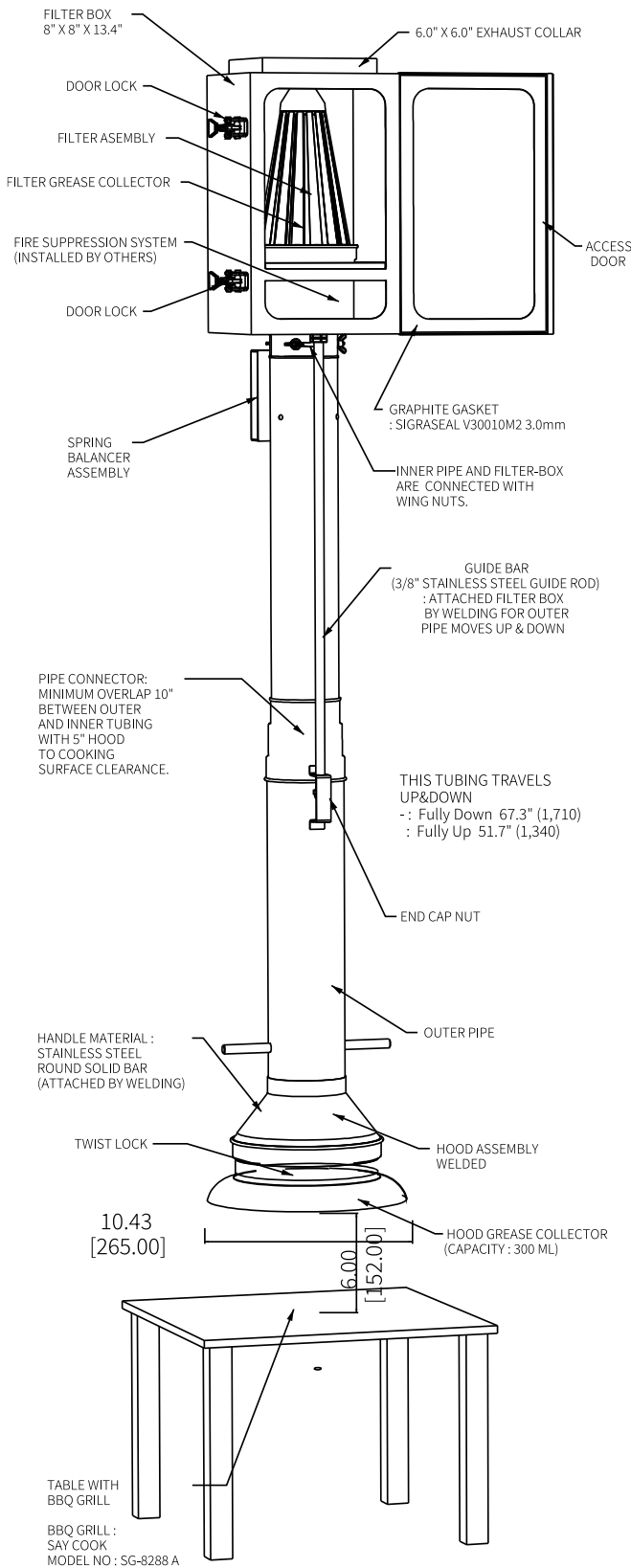

GREASE FILTER ASSEMBLY

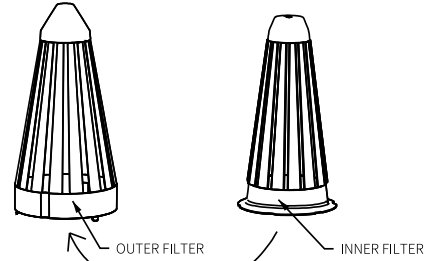

ASSEMBLE THE INNER FILTER INTO THE OUTER FILTER

PLACED ON FILTER GREASE COLLECTOR

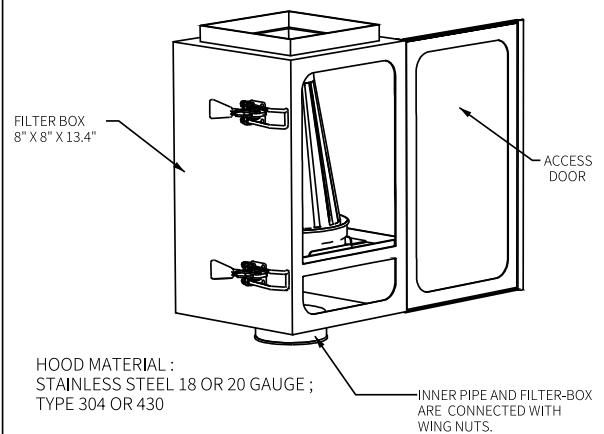
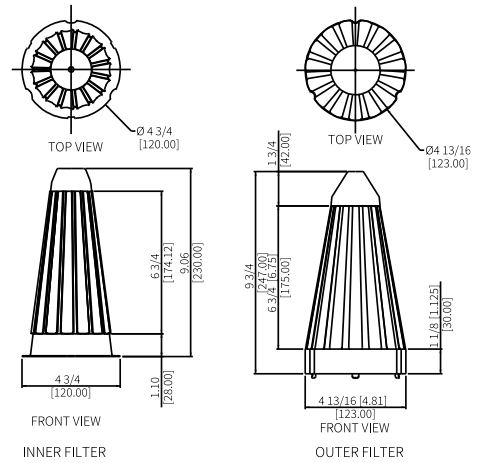
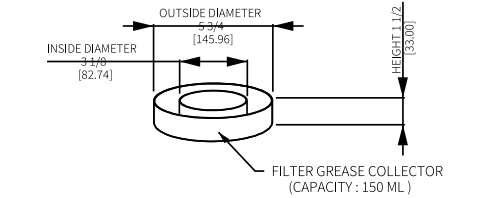

Cleaning Method

✕ Lower Grease Collector

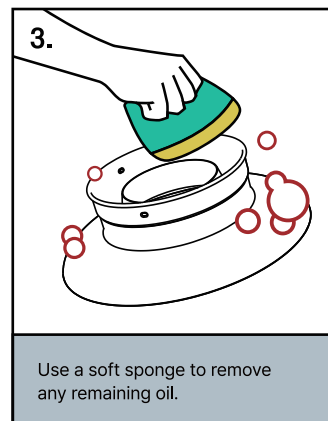
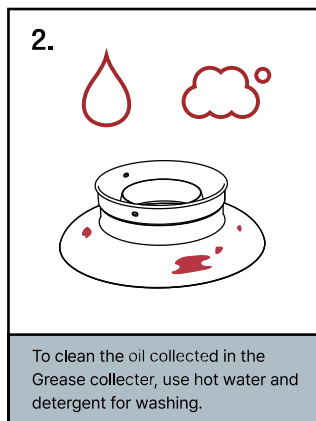
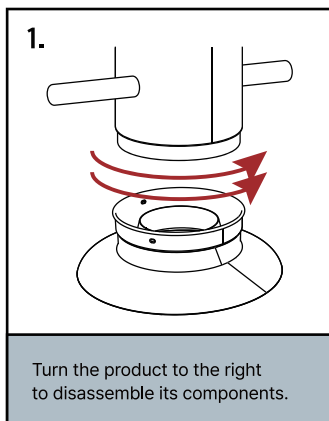

✕ Filter box and Filter

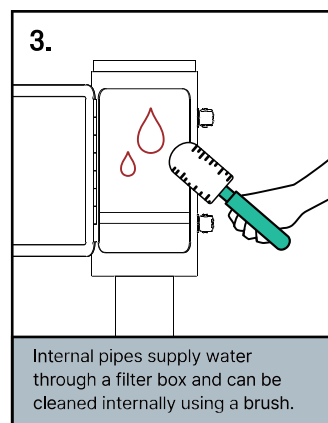
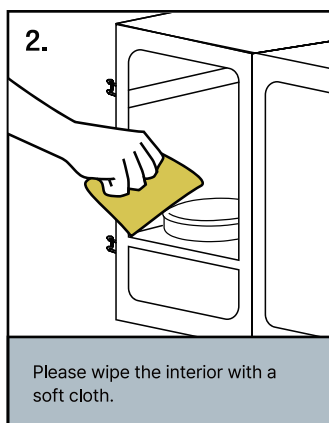
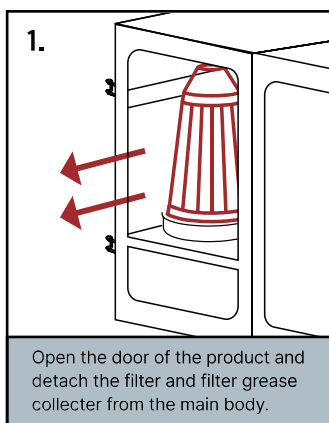

✕ Pipe

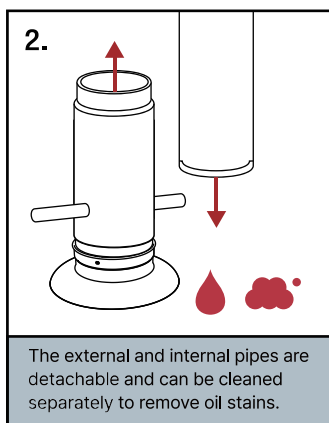
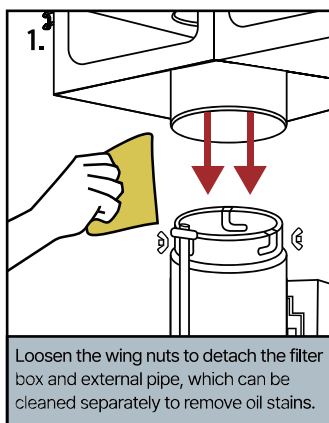

3. To detach the internal pipe (upper) from the external pipe (lower) slightly lift the pipe connection then turn the external pipe to the left and pull it down to separate.
4. The ball bearing can be separated from the pipe by applying force from the inside to the outside.
If oil stains are not completely removed the parts can be replaced through additional purchase.
5. When cleaning the pipe connection wrap a cleaning cloth around a stick and gently wipe the gap between the internal pipe and the pipe connection.

Components

The model SavorX-Monster Detach Pro comes with the filter box and pipe provided as separate parts.

SavorX-Monster Detach Pro is packaged in one box per set.

- Box Dimensions: 280(W) x 280(V) x 1250(H) (mm) / 13.5Kg
11" x 11" x 49.2" (in) /30 (Lbs)

Box Configuration

- Filter Box: Filter box, internal grease filter, external grease filter, filter grease collector, door lock
- Top Pipe: Inner pipe, Ball bearing, Spring balancer, Spring balancer bracket, Guide bar, Wing nut
- Bottom Pipe: Outer pipe, pipe connector, handles, Bottom grease collector, Wire bracket, Guide bar bracket

Itemized Product Components	Component Names	Count
Filter Box	Filter Box	1
	Inner grease filter	1
	Outer grease filter	1
	Filter grease collector	1
	Door Lock	2
Top Pipe	Inner Pipe	1
	Ball bearing	10
	Spring balancer	1
	Spring balancer bracket	1
	Guide bar	1
	Wing Nut	3
Bottom Pipe	Outer Pipe	1
	Pipe Connector	1
	Handle	2
	Bottom grease collector	1
	Wire bracket	1
	Guide bar bracket	1

Assembly Instructions

- After removing the product from the packaging box, verify that all necessary components for installation are included.
- When assembling, ensure that the 6" x 6" exhaust collar (located on the filter box) is securely fixed to the ceiling before installing the product.

1. Assembly of the Filter Box and Duct Hood

- It is recommended to use a 6" x 6" duct size for connecting to the SavorX-Monster Detach Pro.
- It is advisable to have two or more people assist with the assembly.
- While one person holds and installs the hood body, the other should use a drill to securely fasten the cover ring with dedicated screws.
- After securely attaching the hood and filter box, perform welding to prevent gas leaks.

2. Assembly of the Upper Filter Box

- Lift the door lock (red handle) to release the binding.
- The door lock can be adjusted by turning the assembled nut to modify the strength of the connection.
- The lid of the filter box features a graphite gasket designed for high-density sealing.
- The internal filter, external filter, and grease collector are packaged separately.
- Ensure all bubble wrap is removed before installation.
- Place the grease collector into the filter box, ensuring that the concave side faces upward.
- Position the cone-shaped filter on top of the grease collector.
- Insert the filter and grease collector into the fire filter box as shown in the image.

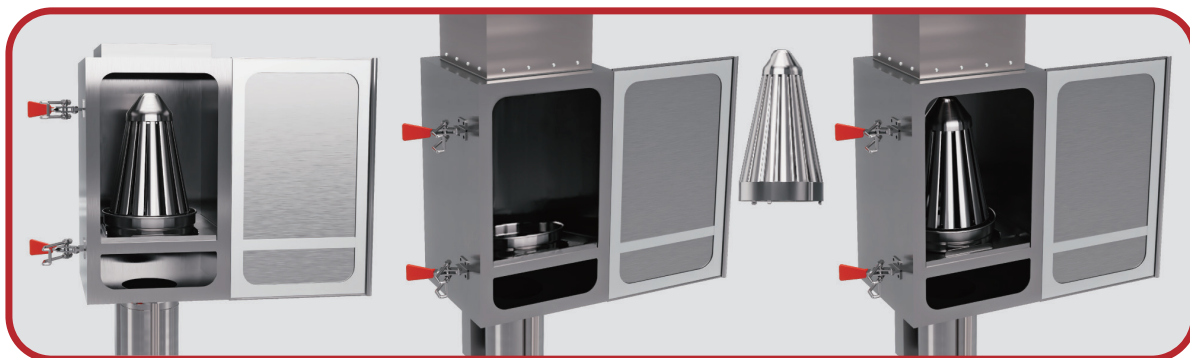

3. Pipe Assembly

- The pipe and filter box are assembled with three wing nuts.

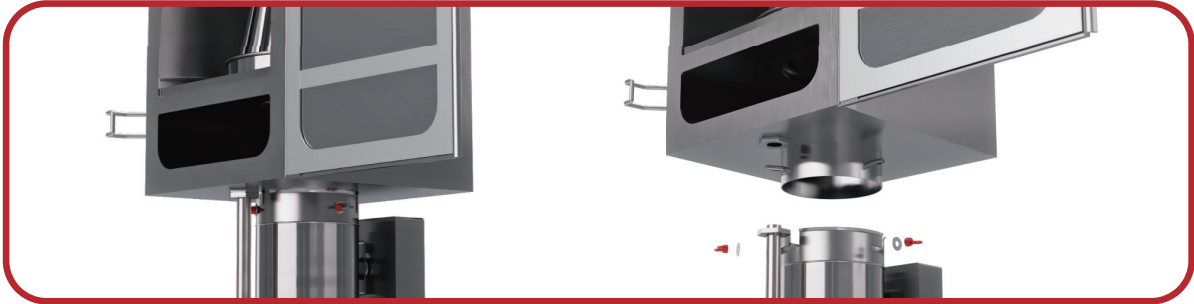

- The height of the hood can be adjusted by the number of installed ball bearings.
- Lift the outer pipe and connect it to the inner pipe, then turn it to the right until it clicks into place to secure it.
- Rotate the pipe connector to the right near the junction of the outer and inner pipes to further secure the connection.



4. Assembly of the Bottom Grease Collector

- Insert the internal part of the grease collector into the interior of the inlet cap.
- Align the grooves below the assembled grease collector and turn it to the right.
- Rotate the bottom grease collector of the bottom pipe to align it with the grooves.
- Ensure that both the upper and lower parts are correctly secured.



Installation and Usage

[When Installing]

Before installing the hood, mark the installation location in advance. The hood operates most effectively when there is a minimum of 6 inches between the cooking equipment (such as a grill) on the table and the bottom of the hood.

- The installer should check all parts and assemble them in the specified order.
- Maintain a minimum distance of 6 inches between the cooking equipment on the table (such as a grill) and the SavorX-Monster Detach Pro during use.

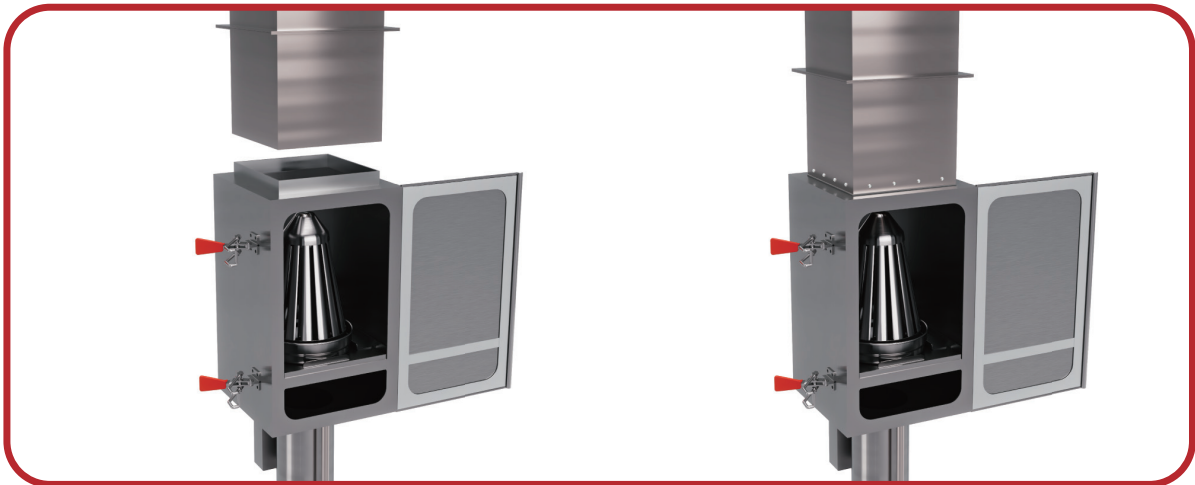

[When Using]

- To adjust the height of the product, hold the handle of the bottom pipe and maneuver it in the desired vertical direction.
- Keep the pipe out of reach of the user while operating the grill.

※ Ensure that the bottom grease collector or inlet cap does not come into direct

Maintenance

- To extend the product's lifespan and maintain a clean operating environment, it is recommended to clean the product regularly.
- Before cleaning and performing maintenance, ensure that the power is turned off to avoid the risk of fire and electric shock.
When turning off the power, disconnect the power plug from the outlet.

ROASTER [SG-8288A]



Intertek
5012198



Intertek
5012198

FEATURES

Charcoal and Gas Dual-Use Downward Roaster :

This roaster evenly cooks both the exterior and interior of the meat on the grill, imparts a charcoal flavor, and expels residual heat and odors through specialized intake holes for downward ventilation, resulting in superior grilling taste compared to other methods.



✓ CHECK POINT

- Large Burner and High Heat for Quick Cooking
- Adopts Dual Safety Fire Extinguishing Device for Maximum Safety
- Modular Design for Easy Cleaning and Partial Maintenance
- Three-Speed Motor Control Ensures Optimal Meat Quality During Grilling
- Forced Ventilation System Expels Smoke and Odors, Providing a Comfortable Indoor Environment
- Chrome-Plated Head Burner for Semi-Permanent Use
- Designed with a Grease Collection Box to Capture Oil in Smoke, Minimizing Grease Accumulation



GAON GRILL

FEATURES

Suitable for semi-permanent use, resistant to warping from heat. It does not worry about coating peeling off and has high thermal conductivity, making it effective for grilling all types of meat, from thick cuts to thin slices.

✓ CHECK POINT

- Excellent Corrosion Resistance
- High Abrasion Resistance
- Great Fire and Heat Resistance
- High Hygiene Standards Easy to Clean



GREASE GUARD

FEATURES

It captures grease and liquid residue to prevent contamination of the cooking appliance. The tray is simple to install and remove, and it can be easily cleaned with water or mild detergent for repeated use. It is made from SUS304 stainless steel, offering excellent heat and corrosion resistance.

✓ CHECK POINT

- Efficient Oil Collection:
- Fire Safety Enhancement:
- Detachable and Easy to Clean:
- Durable Material:

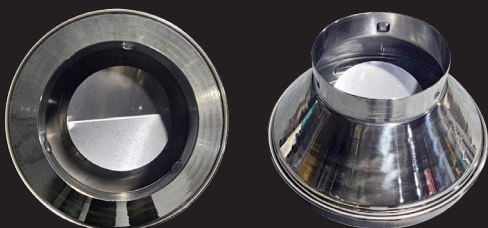

► When the Grease guard is inserted into the Intel Cap & Bottom Grease Collector



gaon
TRADING

Homepage www.gaonhoods.com (ENG) / www.gaoncook.com (한국어)

E-mail gaon.office01@gmail.com

Office (+82)62-719-3030 **Fax** (+82)62-719-3039

Dir (+82)10-5426-1299